

ORION STEEL VALVES

Rising Stem Ball Valves

RSBV



RISING STEM BALL VALVES

Class ASME 150 (PN 20) • 300 (PN 50) • 600 (PN 100) • 900 (PN 150) • 1500 (PN 250) • 2500 (PN 420)

ORION STEEL VALVES
Rising Stem Ball Valves
RSBV

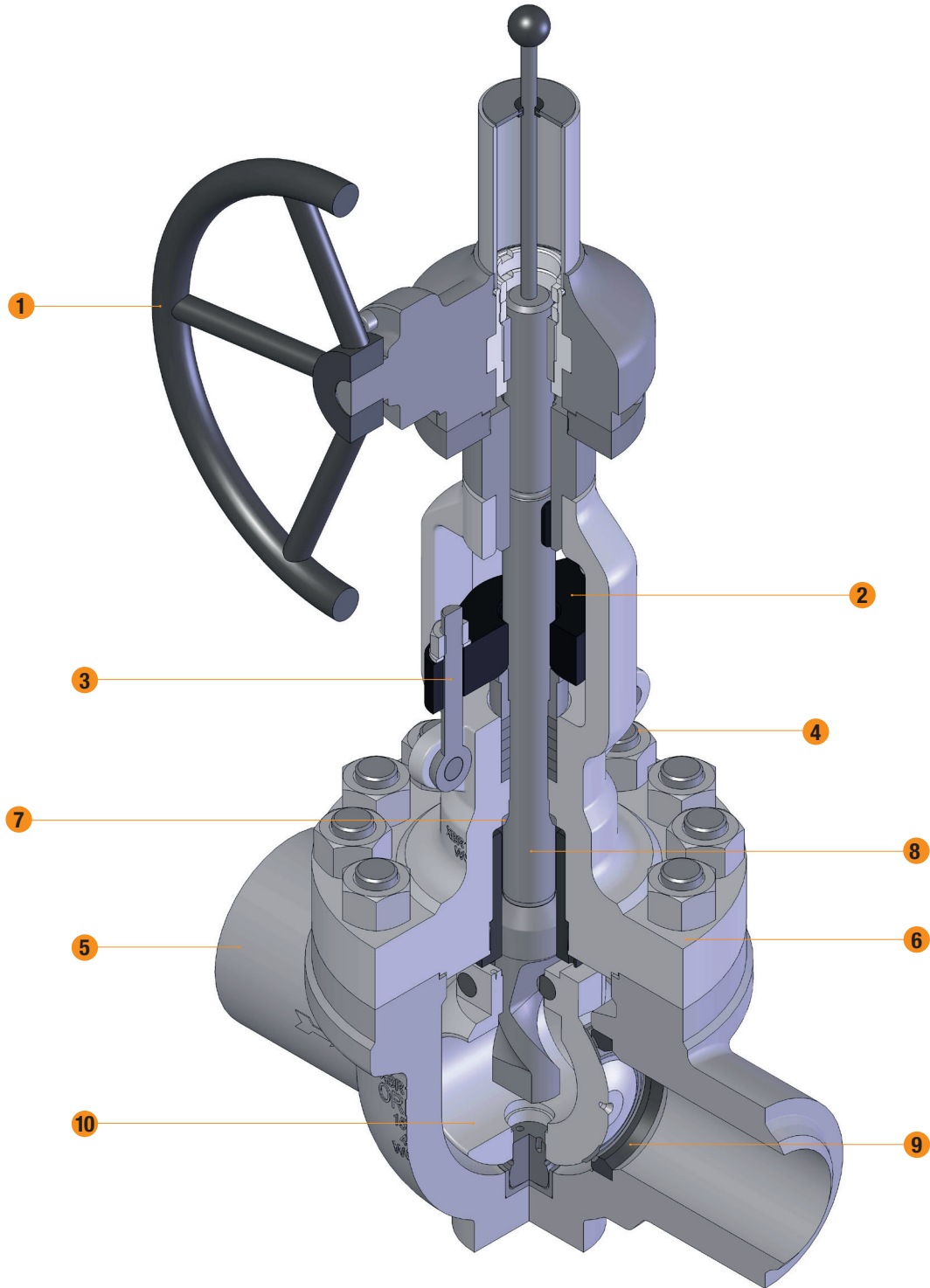

CAST OR FORGED STEEL BODY, OUTSIDE SCREW AND YOKE, RISING STEM, NON-RISING OPERATOR, RENEWABLE SEATS, REMOVABLE YOKE SLEEVE, BACKSEAT FOR REPACKING UNDER PRESSURE.

- 1 OPERATOR** From manual to electric operated the valve can be supplied in many actuations options.
 - 2 GLAND AND GLAND FLANGE** They are in cast and forged steel and are as standard supplied in two pieces, self aligning design to permit the gland to descend parallel to the stem even if the eyebolts are unevenly tightened.
 - 3 GLAND BOLTS AND NUTS** The forged steel gland bolts are of the eyebolt type which can be swung outward for ease of gland repacking. They are fixed to the bonnet by hinge pins.
 - 4 BONNET BOLTING** Bonnet studs and nuts are manufactured from alloy steel to the relevant ASTM standard. The body to bonnet connection is designed according to ASME VIII DIV 1 standard.
 - 5 BODY** The body is in carbon or stainless steel and is available in many other CRA. It is carefully designed for total reliability and simple maintenance. The basic dimension, i.e. wall thickness, face to face and flanges comply with the relevant API and ASME standards. The body-to-bonnet flange is circular, except in the Class 150 where it is oval. The body-to-bonnet joint are flat face on Class 150 valves, male-and-female on Class 300 and ring joint on Class 600 and above. The body is basically supplied with renewable seats. Bosses are provided for drain taps or by-pass piping. The internal surfaces in contact with the fluid can be fully lined or clad for improved corrosion or erosion resistance.
 - 6 BONNET** As the body, the bonnet is in carbon or stainless steel and is available in many other CRA. It is machined to accept yoke sleeve and incorporates a stuffing box sized in accordance with the API standard. Lifting lugs can be provided integrally cast on the bonnet surface.
 - 7 BACKSEAT** The bonnet bushing or backseat is part of the valve trim. Its design allows valve repacking without valve's bleeding or draining. Hardfacing can be provided on stem seating surface.
 - 8 STEM** The peculiar shape of the stem is the evolution of the rising stem ball valve from its traditional design used by other manufacturers. The top of the helix is designed with a flat surface that wedges the ball against the seat. The valve is therefore torque-seated, ensuring a high tightness, independently by differential pressure. The stem of Orion's RSBV makes only a small axial movement when opened and closed. The stem is always balanced NO stem rotation occurs in combination with axial movement when opening and closing, giving in this way better performance in terms of material wear and fugitive emission, the travel is optimized to the minimum in order to fit smaller & reduce cycling time.
 - 9 SEAT RINGS** Welded-in seat rings are supplied as a standard. The rings are part of the trim of the valve. They can be externally threaded and internally notched for easy installation and dismantling or alternatively with press-fit design for easy replacement. Special attention is given to the seating surfaces which are ground and lapped for a tight seal.
 - 10 BALL** The particular spherical closure is rotating around a lower trunnion and the stem outer diameter. The ball during opening and closing operations do not contacts the seat. Only when in full close position it is wedged against the seat for effective sealing of the valve. The circular opening allows a trough conduit design for minimal pressure losses when fully opened, The seating surface of the ball can be hard surfaced in base of any particular need.
 - OPTIONALS** A lantern ring is supplied upon request, in this case the stuffing box shall be drilled, tapped and fitted with an 1/4" NPT plug or grease fitting. Auxiliary connections can be provided on the body when requested.
-

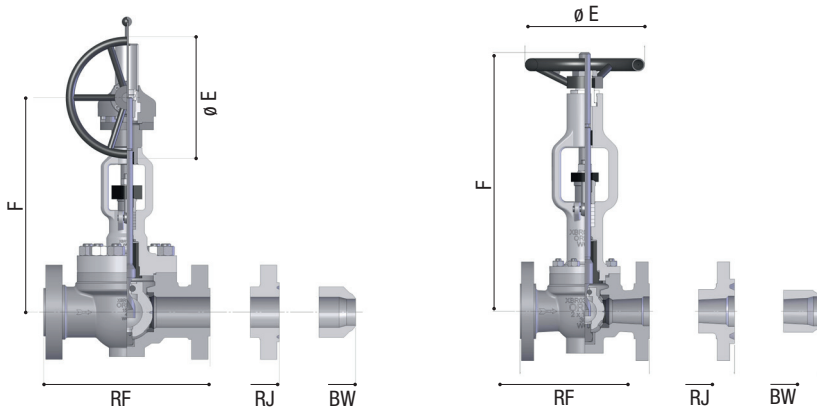

Class ASME 150 (PN 20)

FIGURE NUMBERS - CLASS ASME 150 - ALL SIZES

BR 150: RF - RAISED FACE • BR 150: BW - WELDING ENDS

SIZE	2"	2.1/2"	3"	4"	6"	8"	10"	12"	14"
RF - BW (1)	178	190	203	229	394	457	533	762	826
RJ (1)	191	203	216	242	407	470	546	775	839
C-closed	357	415	573	600	780	862	1250	1650	1730
D-open	417	490	638	662	852	950	1360	1835	1930
E	200	200	200	300	350	400	500	630	710
F	/	/	/	/	/	/	1310	1620	1740
Approximate WEIGHT (Kg)									
FLANGED	40	55	60	110	220	320	690	985	1240
BW									

SIZE	16"	18"	20"	24"
RF - BW (1)	902	914	991	1170
RJ (1)	915	927	1004	1183
C-closed	1800	1910	2040	2150
D-open	2010	2080	2290	2450
E	710	800	800	800
F	1830	1930	2130	2250
Approximate WEIGHT (Kg)				
FLANGED	1910	2560	3800	5630
BW				

Class ASME 300 (PN 50)

FIGURE NUMBERS - CLASS ASME 300 - ALL SIZES

BR 300: RF - RAISED FACE • BR 300: BW - WELDING ENDS • BR 300: RJ - RING JOINT

SIZE	2"	2.1/2"	3"	4"	6"	8"	10"	12"	14"
RF - BW (1)	216	241	282	305	403	502	568	762	826
RJ (1)	232	257	298	321	419	518	584	778	842
C-closed	357	415	573	600	780	920	1250	1650	1730
D-open	417	490	638	662	852	950	1360	1835	1930
E	200	200	200	300	500	630	630	710	710
F	/	/	/	/	783	910	1310	1620	1740
Approximate WEIGHT (Kg)									
FLANGED	45	65	80	110	240	520	715	1250	2140
BW									

SIZE	16"	18"	20"	24"
RF - BW (1)	902	914	991	1143
RJ (1)	918	930	1010	1165
C-closed	1800	1910	2040	2150
D-open	2010	2080	2290	2450
E	800	800	800	800
F	1830	1930	2130	2250
Approximate WEIGHT (Kg)				
FLANGED	3580	4540	4950	5680
BW				

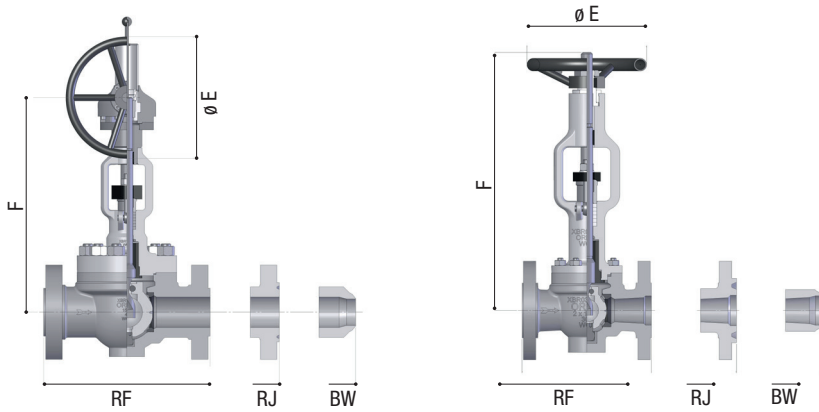

Class ASME 600 (PN 100)

FIGURE NUMBERS - CLASS ASME 600 - ALL SIZES

BR 600: RF - RAISED FACE • BR 600: BW - WELDING ENDS • BR 600: RJ RING JOINT

SIZE	2"	2.1/2"	3"	4"	6"	8"	10"	12"	14"
RF - BW (1)	292	330	356	432	559	660	787	838	889
RJ (1)	295	333	359	435	562	663	790	841	892
C-closed	357	415	573	600	780	920	1250	1650	1730
D-open	417	490	638	662	852	950	1360	1835	1930
E	250	250	300	300	500	710	710	800	800
F	/	/	/	600	783	910	1310	1620	1740
Approximate WEIGHT (Kg)									
FLANGED	90	100	115	150	350	580	890	1800	2100
BW									

SIZE	16"	18"	20"	24"
RF - BW (1)	991	1092	1194	1397
RJ (1)	994	1095	1200	1407
C-closed	1800	1910	2040	2150
D-open	2010	2080	2290	2450
E	800	800	800	900
F	1830	1930	2130	2250
Approximate WEIGHT (Kg)				
FLANGED	2950	5050	5980	7500
BW				

BG: bevel gear operated.

(1) The flanged version of the valve may require the flange holes to be drilled and tapped. For through-drilled flanges it is required to choose a reduced bore valve or a non-standard end-to-end dimension. Values in table are indicated for through drilled holes.

For size and pressure classes non mentioned in the above tables please contact Orion.

NB: all dimension are given in millimeters, weight are expressed in Kg, and are not including the operator.

Dimensions and weight may change from above values without notice.

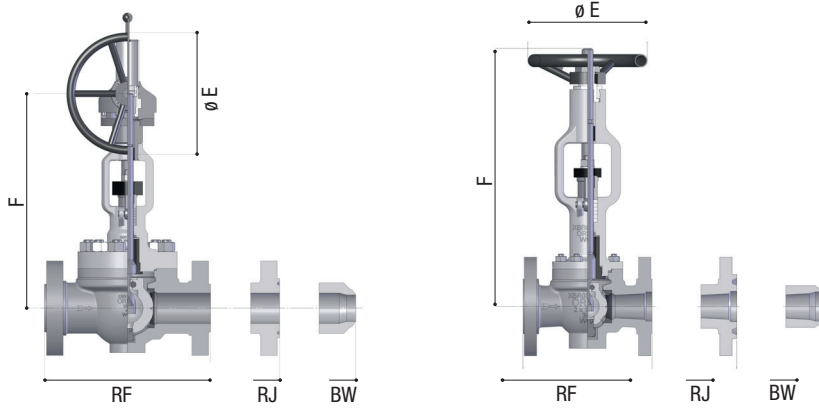

Class ASME 900 (PN 150)

FIGURE NUMBERS - CLASS ASME 900 - ALL SIZES

BR 900: RF - RAISED FACE • BR 900: BW - WELDING ENDS • BR 900: RJ - RING JOINT

SIZE	2"	2.1/2"	3"	4"	6"	8"	10"	12"	14"
RF - BW (1)	368	419	381	457	610	737	838	965	1029
RJ (1)	371	422	385	460	613	740	841	968	1039
C-closed	430	530	590	715	1002	1250	1345	1530	1640
D-open	474	580	640	780	1121	1380	1500	1650	1914
E	200	200	400	500	630	630	630	710	710
F	400	500	620	700	1003	1252	1415	1550	1650
Approximate WEIGHT (Kg)									
FLANGED	135	155	180	220	450	725	1500	2200	3500
BW	118	138	164	191	385	621	1360	2010	3275

SIZE	16"	18"	20"	24"
RF - BW (1)	1130	1219	1321	1549 (*)
RJ (1)	1140	1232	1334	1568 (*)
C-closed	1780	1890	2320	2471
D-open	2150	2420	2590	2700
E	800	800	800	1000
F	1815	1920	2120	2224
Approximate WEIGHT (Kg)				
FLANGED	4280	5600	6800	7150
BW	3848	5160	6340	6310

BG: bevel gear operated.

(1) The flanged version of the valve may require the flange holes to be drilled and tapped. For through-drilled flanges it is required to choose a reduced bore valve or a non-standard end-to-end dimension. Values in table are indicated for through drilled holes.

Values marked with (*) require tapped holes

For size and pressure classes non mentioned in the above tables please contact Orion

NB: all dimension are given in millimeters, weight are expressed in Kg, and are not including the operator

Dimensions and weight may change from above values without notice.

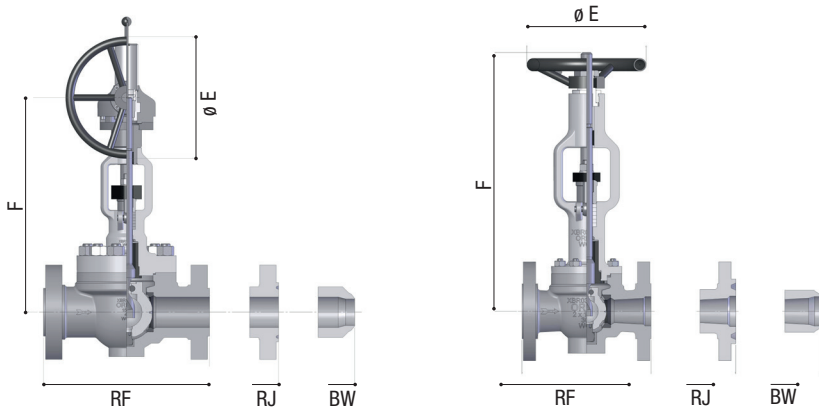

Class ASME 1500 (PN 250)

FIGURE NUMBERS - CLASS ASME 1500 - ALL SIZES BR 1500: RF - RAISED FACE • BR 1500: BW - WELDING ENDS • BR 1500: RJ RING JOINT

SIZE	2"	2.1/2"	3"	4"	6"	8"	10"	12"
RF - BW (1)	368	419	470	546	705	832	991	1130
RJ (1)	371	422	473	549	711	842	1001	1146
C-closed	430	530	590	715	1002	1250	1345	1410
D-open	474	580	640	780	1121	1380	1500	1575
E	200	200	400	500	630	630	630	710
F	400	500	620	700	1003	1252	1415	1550
Approximate WEIGHT (Kg)								
FLANGED	135	170	220	280	580	1420	2270	3900
BW								

SIZE	14"	16"
RF - BW (1)	1257	1384
RJ (1)	1276	1406
C-closed	1725	1950
D-open	1914	2150
E	710	800
F	1850	2300
Approximate WEIGHT (Kg)		
FLANGED	5200	8150
BW		

Class ASME 2500 (PN 420)

FIGURE NUMBERS - CLASS ASME 2500 - ALL SIZE BR 2500: RF - RAISED FACE • BR 2500: BW - WELDING ENDS • BR 2500: RJ - RING JOINT

SIZE	2"	2.1/2"	3"	4"	6"	8"	10"	12"
RF - BW (1)	451	508	578	673	914	1022	1270	1422
RJ (1)	454	514	584	683	927	1038	1292	1444
C-closed	450	554	620	950	1320	1620	1800	1930
D-open	495	620	700	1050	1435	1740	1930	2130
E	300	350	400	450	630	710	800	800
F	460	580	750	945	1340	1660	1820	1950
Approximate WEIGHT (Kg)								
FLANGED	150	195	230	450	1.030	1.920	3.265	5.200
BW								

BG: bevel gear operated.

(1) The flanged version of the valve may require the flange holes to be drilled and tapped. For through-drilled flanges it is required to choose a reduced bore valve or a non-standard end-to-end dimension. Values in table are indicated for through drilled holes.

For size and pressure classes non mentioned in the above tables please contact Orion.

NB: all dimension are given in millimeters, weight are expressed in Kg, and are not including the operator.

Dimensions and weight may change from above values without notice.

