

ORION STEEL VALVES
Butterfly
API 609



BUTTERFLY BUTTWELD VALVES API 609 - p. 178

Class ANSI 150 (PN 20) • 300 (PN 50) • 600 (PN 100)

BUTTERFLY WAFER VALVES API 609 - p. 186

Class ANSI 150 (PN 20) • 300 (PN 50) • 600 (PN 100)

BUTTERFLY FLANGED VALVES API 609 - p. 182

Class ASME 150 (PN 20) • 300 (PN 50) • 600 (PN 100)

BUTTERFLY SIDE ENTRY VALVES API 609 - p. 178

Class ASME 150 (PN 20)

ORION STEEL VALVES
Butterfly
API 609

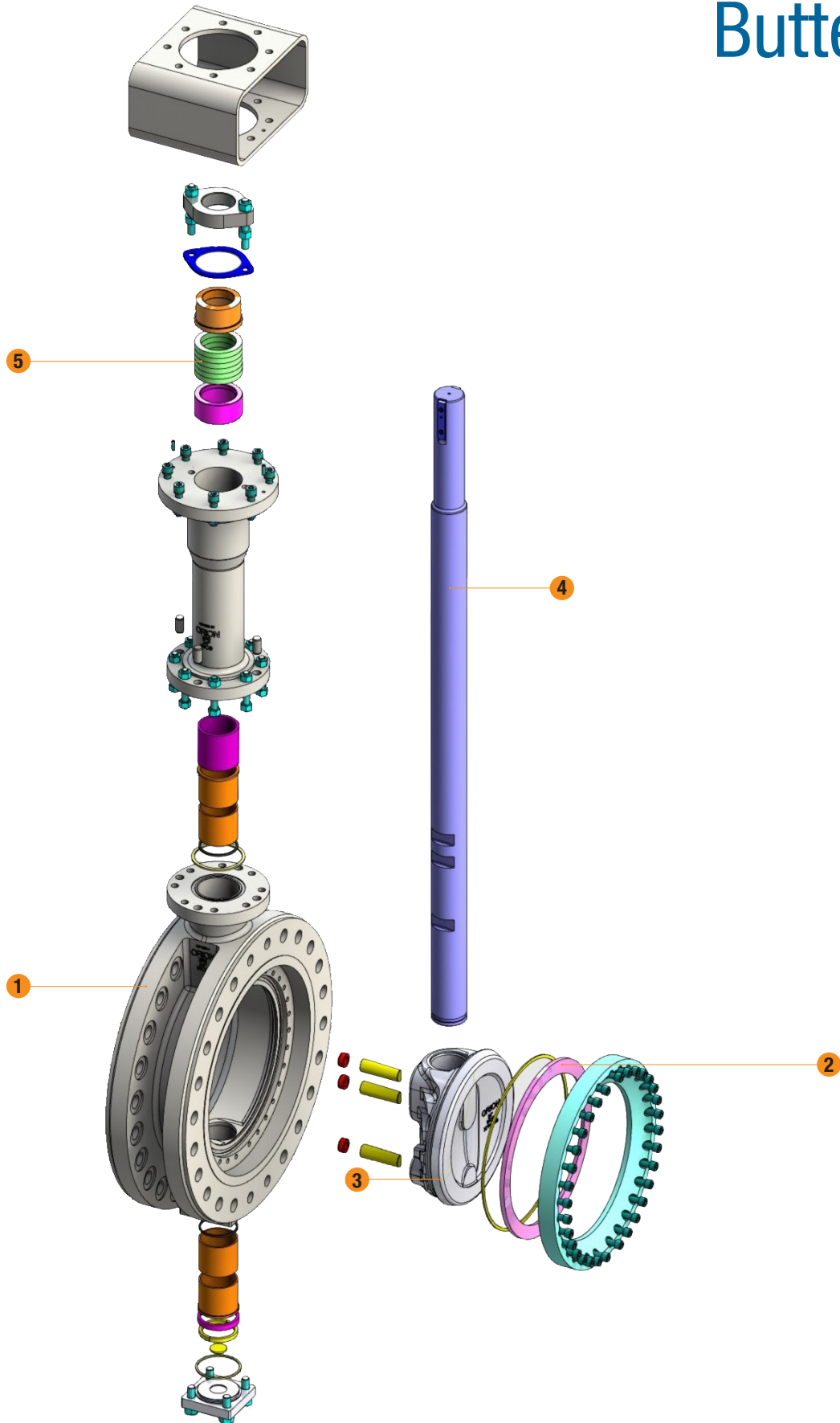

1 VALVE BODY

The body is cast in carbon or stainless steel and is also available in many other CRA. For severe services and large valve sizes it can be internally lined or fully clad instead of having solid CRA. The internal profile is designed in order to minimize pressure losses, and basic dimensions (face to face and wall thickness) comply with API 609 and ISO5752 standards. Body style can be wafer or wafer LUG type, flanged, or butt-weld. Body connections can be provided as per ASME B 16.5 RF or RTJ, as well as BW end or hub connection are available.

2 SEAT INSERT

The seat insert can be proposed with different solutions, against different service severity scenarios. A plastic (PTFE/PEEK/PA/...) insert can be chosen as well as laminated graphite/metallic inserts, for metal to metal seating.

The seat insert is located in the body, to enhance the tightness capability, been working in expansion only. For wafer style valves only, it is located on the disc.

Seating geometry is of triple eccentric type, ensuring the best result in terms of seating effort against tightness level achievable.

3 DISC

The disc is the main part of the trim and allows fluid control, as well as tight shut off capability. It comes in forged or cast steel or CRA for diameters up to 12" and in cast steel for larger diameters.

Its shape is optimized in order to avoid turbulences and is assisted by a spring in closed position. Each component is verified with Fem-FEA analysis in order to deliver the seating torque uniformly to the seat and ensure the highest rigidity against both seating directions.

4 STEM

The valve is operated through the stem rotation, which hold the pressure thrust and increase the disc stiffness. Stem is connected to the disc through non-shear pins, which increase the torsional resistance of the stem and do not transmit the torque through shear resistance of the pins.

5 STEM SEAL

The stem is sealed through an O-Ring arrangement for regular temperature applications and mild environments. An energized lip seal is used for low torque demand and/or cryogenic services.

For high temperatures, fire safe design, or when a stuffing box is preferred, a graphite packing is provided, with the top level FE qualifications in order to reduce fluid losses.

OPERATOR

The quarter turn operators are worm type gearboxes. The valve can be easily interfaced with electric or linear actuators through standard ISO5211 flange.

INSTALLATION REMARKS

The valve is designed to bear pressure in both direction, although the preferred pressure direction is giving extended valve life and reduced operating torques. The torque figures can be custom fit to the specific operating direction, so a unidirectionally built valve could not be reversible.

ORION STEEL VALVES
Butterfly
BUTTWELD API 609

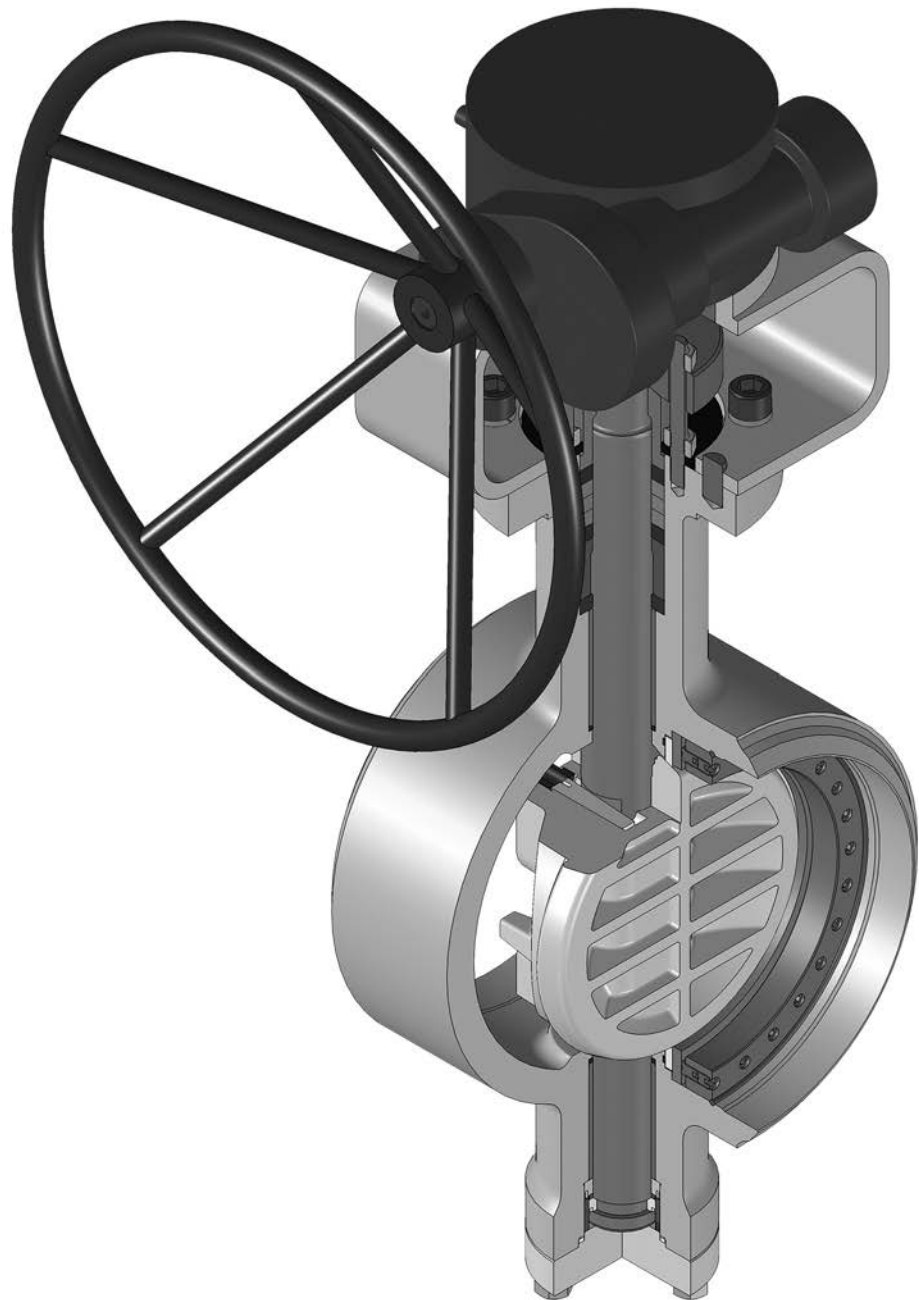

SEAT INSERT

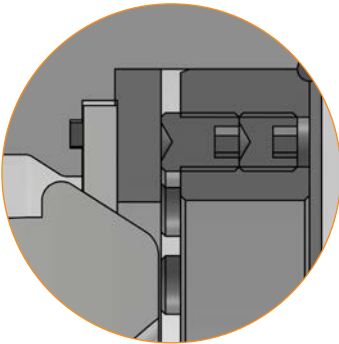

DISC TO STEM LINKAGE

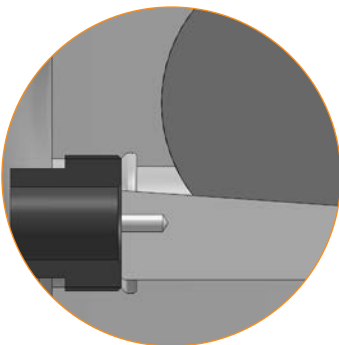

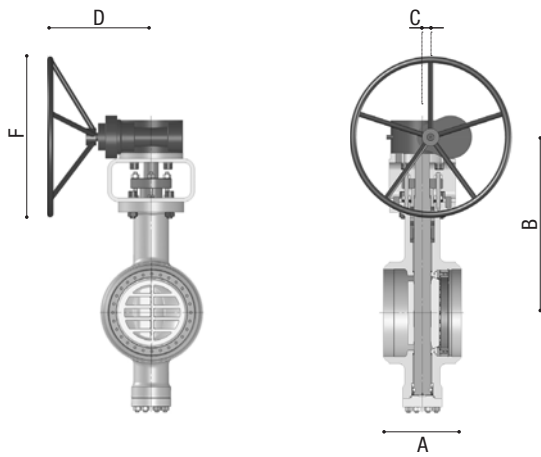

Class ASME 150 (PN 20)

FIGURE NUMBERS - CLASS ASME 150 - ALL SIZES

BY 150 BW - BUTTWELD

SIZE	3"	4"	6"	8"	10"	12"	14"	16"	18"
A	180	190	210	230	250	270	290	310	330
B	250	315	331	380	410	451	527	562	625
C	57	57	57	70	97	127	127	153	60
D	150	150	150	300	350	400	500	500	700
Approximate WEIGHT (Kg)									
BUTTWELD END	22	25	46	68	121	142	194	251	340

SIZE	20"	24"
A	350	390
B	659	763
C	60	230
D	700	800
Approximate WEIGHT (Kg)		
BUTTWELD END	515	630

LO: lever operated

BG: bevel gear operated.

For size and pressure classes non mentioned in the above tables please contact Orion

NB: all dimension are given in millimeters, weight are expressed in Kg, and are not including the operator.

Dimensions and weight may change from above values without notice.

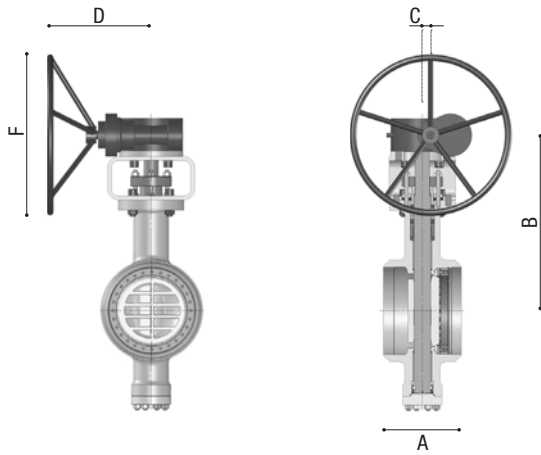

Class ASME 300 (PN 50)

FIGURE NUMBERS - CLASS ASME 300 - ALL SIZES

BY 300 BW - BUTTWELD

SIZE	3"	4"	6"	8"	10"	12"	14"	16"	18"
A	180	190	210	230	250	270	290	310	330
B	268	282	426	470	620	814	839	864	890
C	57	57	70	97	97	112	127	153	180
D	150	150	300	400	500	600	700	500	500
Approximate WEIGHT (Kg)									
BUTTWELD END	26	33	68	90	104	158	215	294	365

SIZE	20"	24"
A	350	390
B	918	965
C	180	202
D	500	710
Approximate WEIGHT (Kg)		
BUTTWELD END	458	785

For size and pressure classes non mentioned in the above tables please contact Orion

NB: all dimension are given in millimeters, weight are expressed in Kg, and are not including the operator.

Dimensions and weight may change from above values without notice.

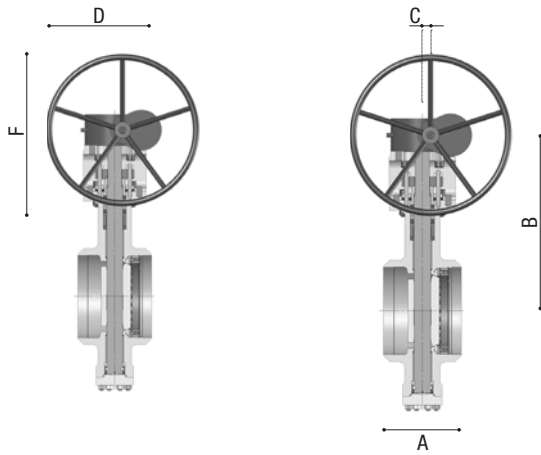

Class ASME 600 (PN 100)

FIGURE NUMBERS - CLASS ASME 600 - ALL SIZES

BY 600 BW - BUTTWELD

SIZE	3"	4"	6"	8"	10"	12"	14"	16"	18"
A	190	210	230	250	270	290	310	330	350
B	320	330	383	521	610	640	678	732	765
C	70	97	153	153	180	230	230	326	326
D	250	300	400	400	500	500	710	710	710
Approximate WEIGHT (Kg)									
BUTTWELD END	49	55	93	179	198	280	318	526	617

SIZE	20"	24"
A	390	432
B	812	884
C	379	379
D	710	710
Approximate WEIGHT (Kg)		
BUTTWELD END	693	1012

For size and pressure classes non mentioned in the above tables please contact Orion

NB: all dimension are given in millimeters, weight are expressed in Kg, and are not including the operator.

Dimensions and weight may change from above values without notice.

ORION STEEL VALVES
Butterfly
FLANGED API 609

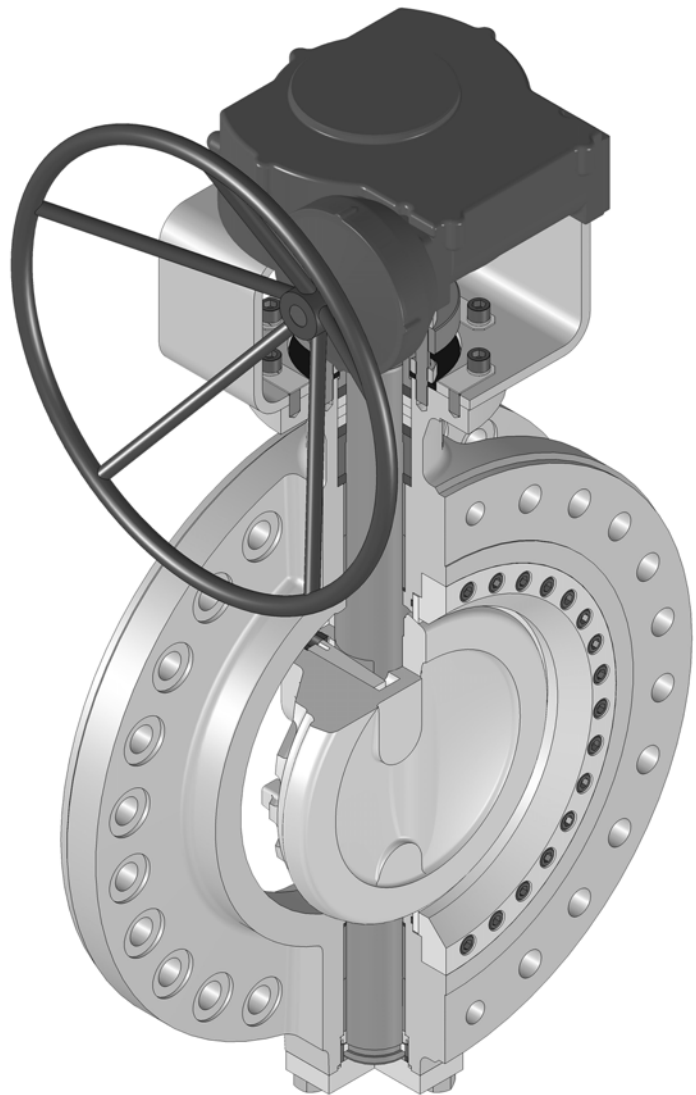

SEAT INSERT

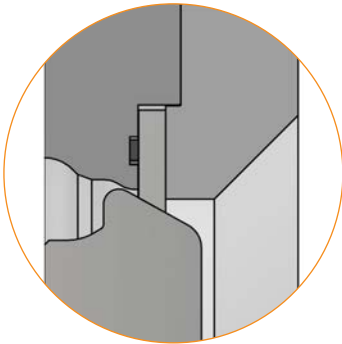

DISC TO STEM LINKAGE

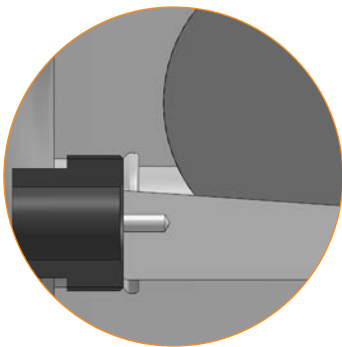

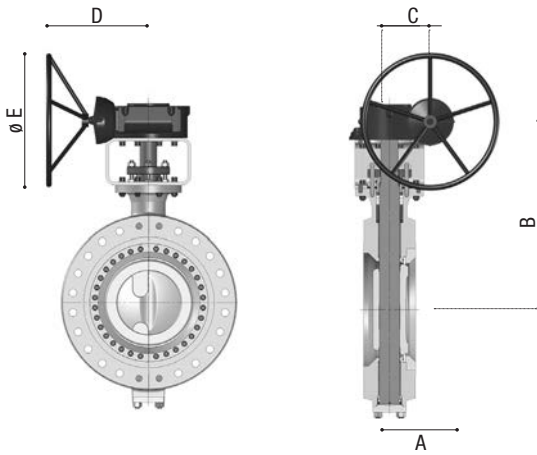

Class ASME 150 (PN 20)

FIGURE NUMBERS - CLASS ASME 150 - ALL SIZES

BY 150 FL - FLANGED

SIZE	3"	4"	6"	8"	10"	12"	14"	16"	18"
A	114	127	140	152	165	178	190	216	222
B	250	315	331	380	410	451	527	562	625
C	57	57	57	70	97	127	127	153	60
D	150	150	150	300	350	400	500	500	700
Approximate WEIGHT (Kg)									
FLANGED	28	35	52	76	131	151	220	270	380

SIZE	20"	24"	28"	30"	36"
A	229	267	292	318	330
B	659	763	902	1121	1356
C	60	230	280	326	380
D	700	800	800	800	710
Approximate WEIGHT (Kg)					
FLANGED	420	651	897	1129	1590

LO: lever operated

BG: bevel gear operated.

(1) The flanged version of the valve may require some of the flange holes to be drilled and tapped. For through-drilled flanges it is required to choose a reduced bore valve or a non-standard end-to-end dimension.

For size and pressure classes non mentioned in the above tables please contact Orion

NB: all dimension are given in millimeters, weight are expressed in Kg, and are not including the operator.

Dimensions and weight may change from above values without notice.

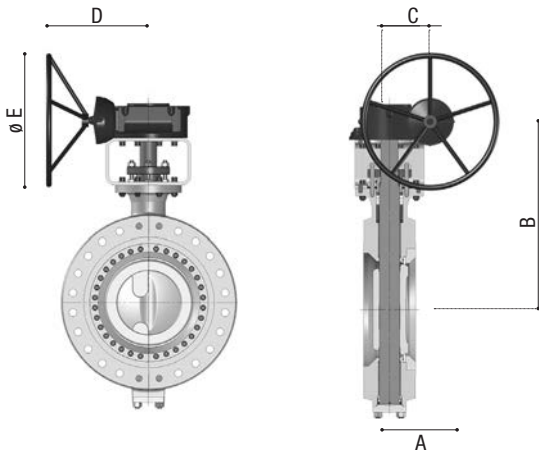

Class ASME 300 (PN 50)

FIGURE NUMBERS - CLASS ASME 300 - ALL SIZES

BY 300 FL - FLANGED

SIZE	3"	4"	6"	8"	10"	12"	14"	16"	18"
A	114	127	140	152	165	178	190	216	222
B	268	282	426	470	620	814	839	864	890
C	57	57	70	97	97	112	127	153	180
D	150	150	300	400	500	600	700	500	500
Approximate WEIGHT (Kg)									
FLANGED	30	43	78	108	145	193	292	456	524

SIZE	20"	24"	28"	30"	36"
A	229	267	292	318	330
B	918	965	1015	1110	1195
C	180	202	230	326	326
D	500	710	710	500	500
Approximate WEIGHT (Kg)					
FLANGED	652	1100	1449	1750	2480

(1) The flanged version of the valve may require some of the flange holes to be drilled and tapped. For through-drilled flanges it is required to choose a reduced bore valve or a non-standard end-to-end dimension.

For size and pressure classes non mentioned in the above tables please contact Orion

NB: all dimension are given in millimeters, weight are expressed in Kg, and are not including the operator.

Dimensions and weight may change from above values without notice.

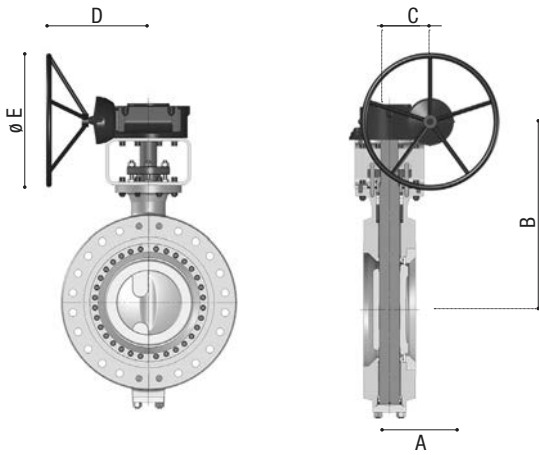

Class ASME 600 (PN 100)

FIGURE NUMBERS - CLASS ASME 600 - ALL SIZES

BY 600 FL - FLANGED

SIZE	3"	4"	6"	8"	10"	12"	14"	16"	18"
A	180	190	210	230	250	270	290	310	330
B	320	330	383	521	610	640	678	732	765
C	70	97	153	153	180	230	230	326	326
D	250	300	400	400	500	500	710	710	710
Approximate WEIGHT (Kg)									
FLANGED	58	65	127	206	392	435	515	720	868

SIZE	20"	24"
A	350	390
B	812	884
C	379	379
D	710	710
Approximate WEIGHT (Kg)		
FLANGED	1168	1720

(1) The flanged version of the valve may require some of the flange holes to be drilled and tapped. For through-drilled flanges it is required to choose a reduced bore valve or a non-standard end-to-end dimension.

For size and pressure classes non mentioned in the above tables please contact Orion

NB: all dimension are given in millimeters, weight are expressed in Kg, and are not including the operator.

Dimensions and weight may change from above values without notice.

ORION STEEL VALVES
Butterfly
WAFER API 609

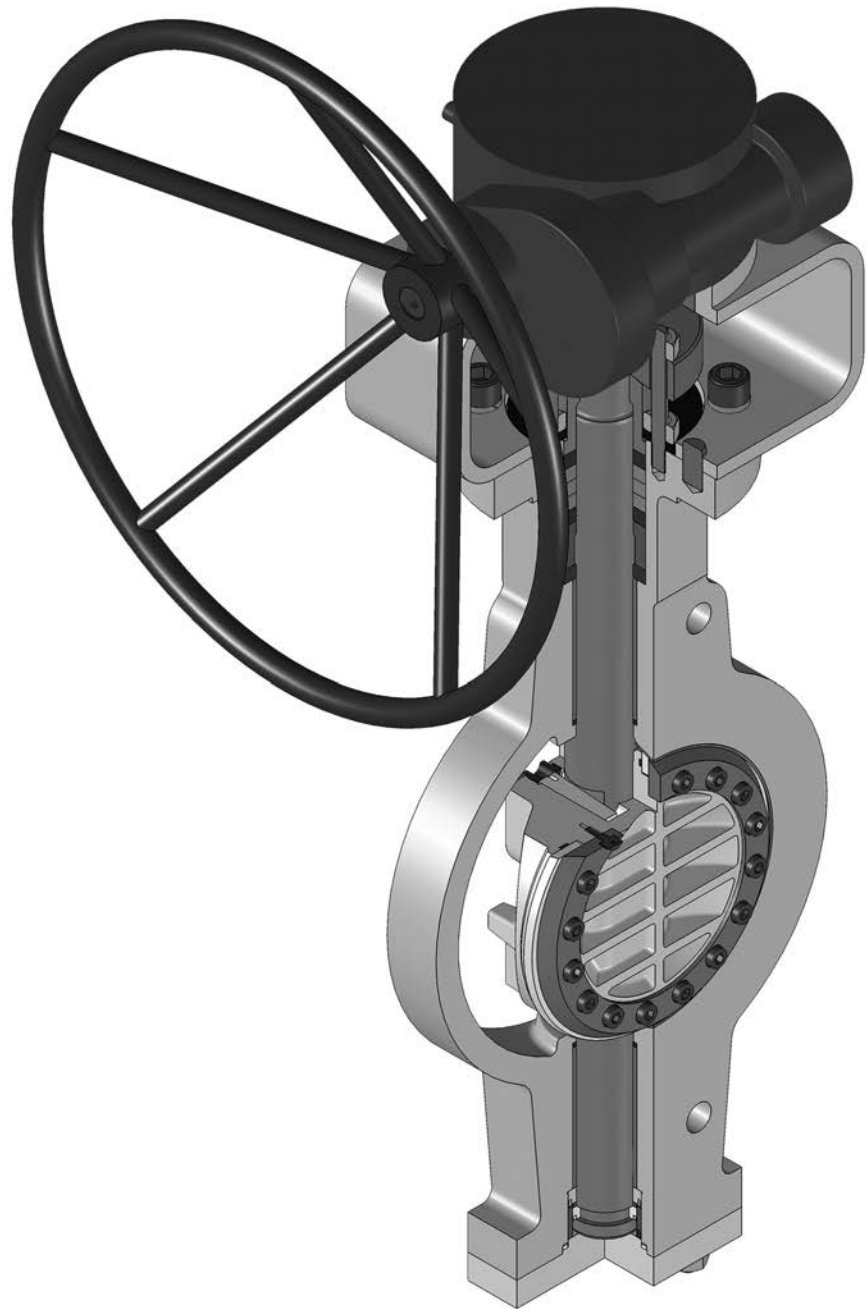

SEAT INSERT

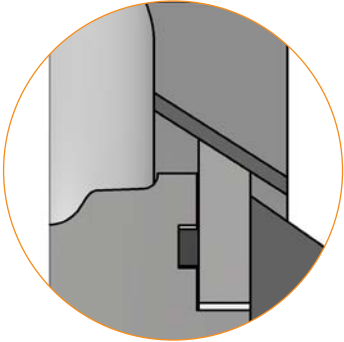

DISC TO STEM LINKAGE

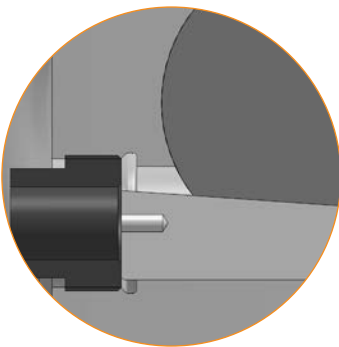

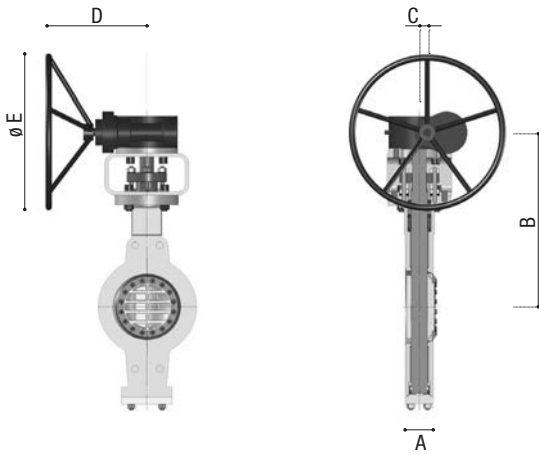

Class ASME 150 (PN 20)

FIGURE NUMBERS - CLASS ASME 150 - ALL SIZES

BY 150 LUG - WAFER LUG

SIZE	3"	4"	6"	8"	10"	12"	14"	16"	18"
A	48	54	57	64	71	81	92	102	114
B	250	315	331	380	410	451	527	562	625
C	57	57	57	70	97	127	127	153	60
D	150	150	150	300	350	400	500	500	700
Approximate WEIGHT (Kg)									
FLANGED	18	25	32	45	70	112	131	182	284

SIZE	20"	24"	28"	30"	36"
A	127	154	165	191	203
B	659	763	902	1121	1356
C	60	230	280	326	380
D	700	800	800	800	710
Approximate WEIGHT (Kg)					
FLANGED	334	532	828	937	1546

LO: lever operated

BG: bevel gear operated.

For size and pressure classes non mentioned in the above tables please contact Orion

NB: all dimension are given in millimeters, weight are expressed in Kg, and are not including the operator.

Dimensions and weight may change from above values without notice.

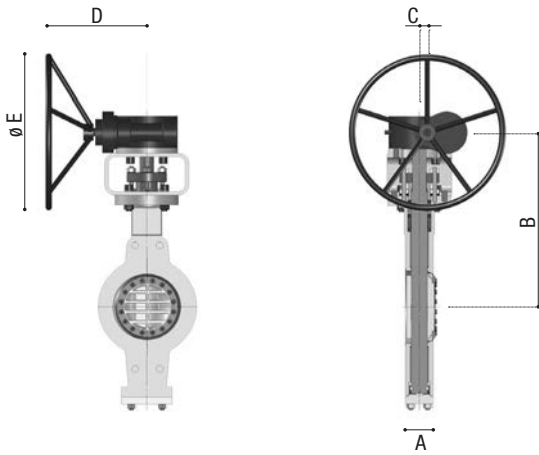

Class ASME 300 (PN 50)

FIGURE NUMBERS - CLASS ASME 300 - ALL SIZES

BY 300 LUG - WAFER LUG

SIZE	3"	4"	6"	8"	10"	12"	14"	16"	18"
A	114	127	140	152	165	178	190	216	222
B	268	282	426	470	620	814	839	864	890
C	57	57	70	97	97	112	127	153	180
D	150	150	300	400	500	600	700	500	500
Approximate WEIGHT (Kg)									
FLANGED	30	43	78	108	145	193	292	456	524

SIZE	20"	24"	28"	30"	36"
A	229	267	292	318	330
B	918	965	1015	1110	1195
C	180	202	230	326	326
D	500	710	710	500	500
Approximate WEIGHT (Kg)					
FLANGED	652	1100	1449	1750	2480

For size and pressure classes non mentioned in the above tables please contact Orion

NB: all dimension are given in millimeters, weight are expressed in Kg, and are not including the operator.

Dimensions and weight may change from above values without notice.

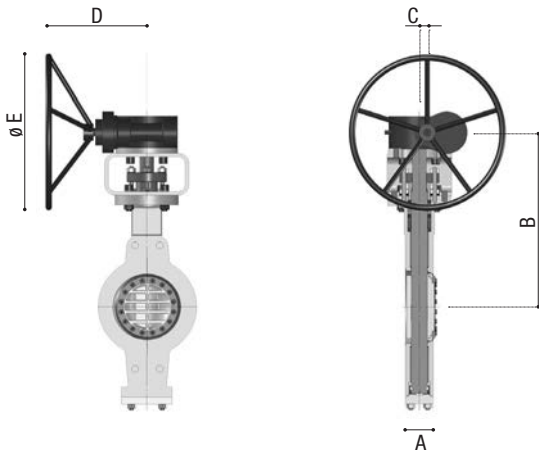

Class ASME 600 (PN 100)

FIGURE NUMBERS - CLASS ASME 600 - ALL SIZES

BY 600 LUG - WAFER LUG

SIZE	3"	4"	6"	8"	10"	12"	14"	16"	18"
A	54	64	78	102	117	140	155	178	200
B	320	330	383	521	610	640	678	732	765
C	70	97	153	153	180	230	230	326	326
D	250	300	400	400	500	500	710	710	710
Approximate WEIGHT (Kg)									
FLANGED	30	36	68	135	198	275	320	458	708

SIZE	20"	24"
A	216	232
B	812	884
C	379	379
D	710	710
Approximate WEIGHT (Kg)		
FLANGED	804	1480

For size and pressure classes non mentioned in the above tables please contact Orion

NB: all dimension are given in millimeters, weight are expressed in Kg, and are not including the operator.

Dimensions and weight may change from above values without notice.

ORION STEEL VALVES
Butterfly
SIDE ENTRY API 609

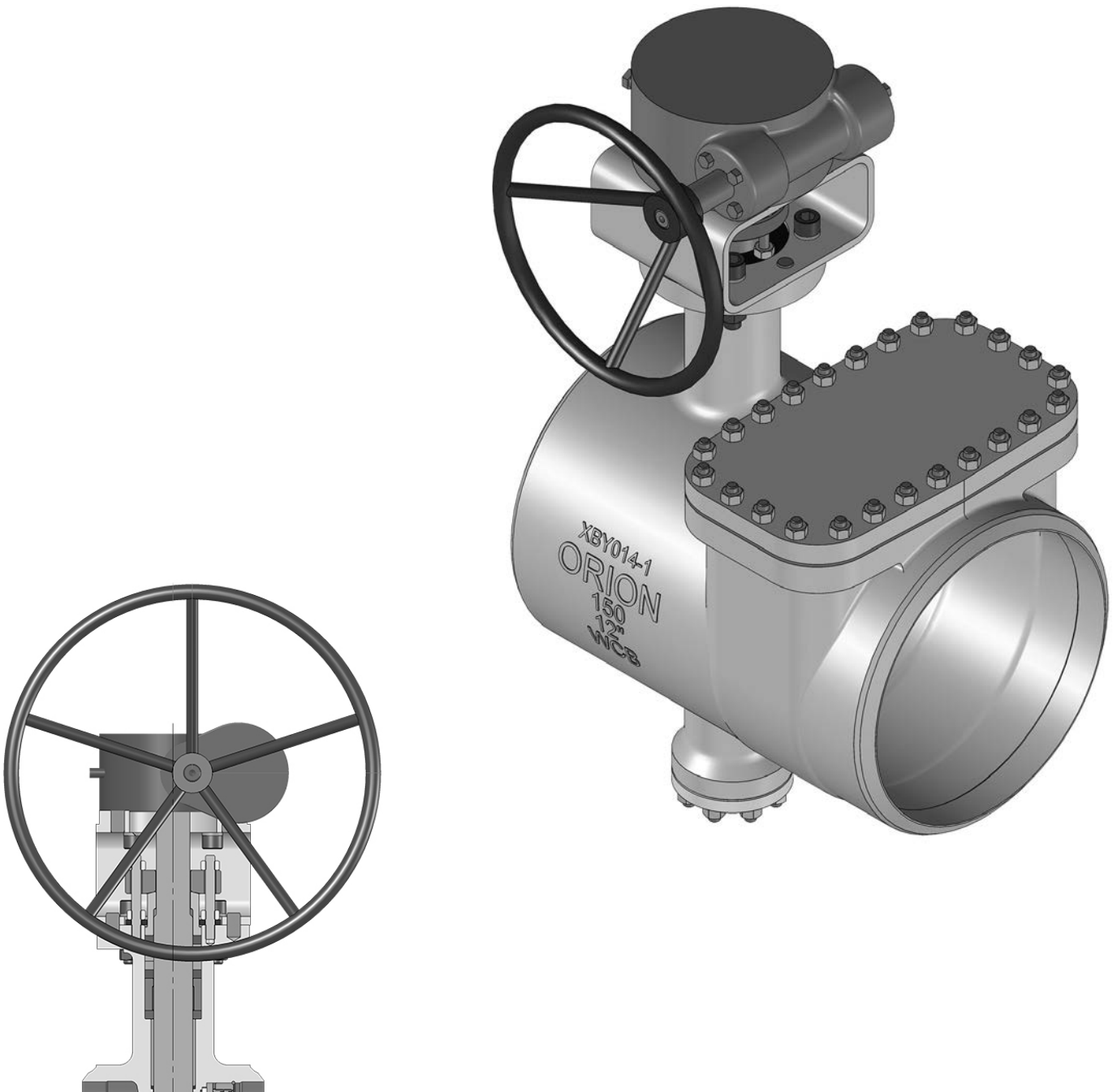

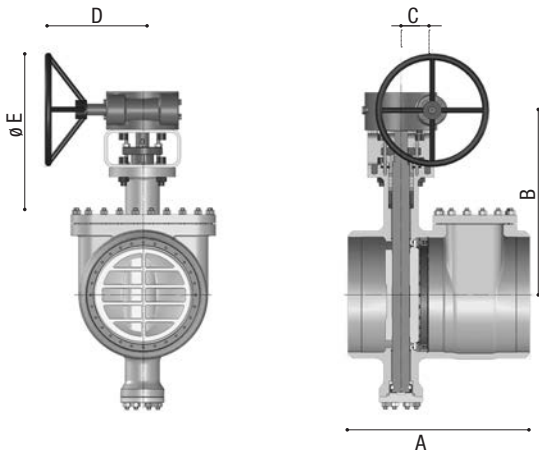

Class ASME 150 (PN 20)

FIGURE NUMBERS - CLASS ASME 150 - ALL SIZES

BY 150 BWIB - BUTTWELD EXTENDED SHAFT WITH INSPECTION BONNET

SIZE	6"	8"	10"	12"	14"	16"	18"	20"	24"
A	400	410	460	480	530	560	590	630	680
B	826	883	948	1014	1080	1113	1180	1263	1350
C	57	70	97	127	127	153	60	60	230
D	150	300	350	400	500	500	700	700	800
Approximate WEIGHT (Kg)									
BUTTWELD END	46	68	121	142	194	251	340	515	630

LO: lever operated

BG: bevel gear operated.

For size and pressure classes non mentioned in the above tables please contact Orion

NB: all dimension are given in millimeters, weight are expressed in Kg, and are not including the operator.

Dimensions and weight may change from above values without notice.